

Current-Mirror Operational Amplifier Design

The current mirror op amp is shown below. This can be used as a standard operational amplifier in a feedback configuration though when it was introduced the primary focus was on using it in open-loop applications as an Operational Transconductance Amplifier.

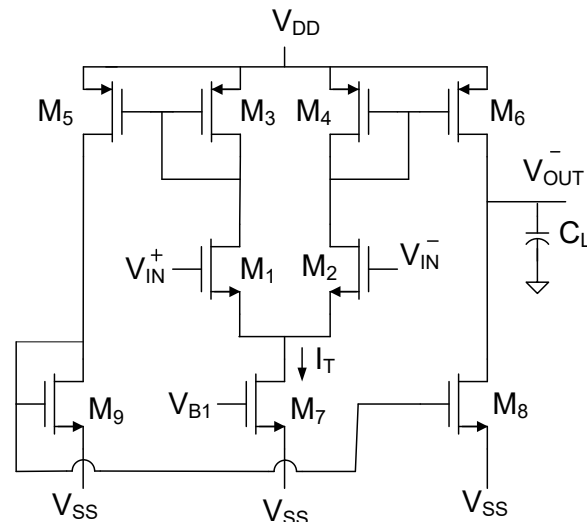

1. Design this op amp in a $0.5\mu\text{m}$ process with supply voltages of $V_{DD}=2.5\text{V}$ and $V_{SS}=-2.5\text{V}$. In this design, the lengths of all devices should be $5xL_{\min}$, the mirror gains M_{35} and M_{46} should be 10, the mirror gain M_{78} should be 1, the power dissipation should be 1mW , and V_{EB} should be 100mV for all devices.
2. Analytically determine the differential voltage gain, the BW, the GB, and the SR of this amplifier. Assume $C_L=20\text{pF}$.
3. Analytically determine the output signal swing for a common-mode input of -200mV .
4. Compare the results obtained in part 2 and part 3 with computer simulations.
5. What is the 3dB bandwidth when feedback is applied to form a unity-gain buffer?

6. What is the response of the unity-gain feedback amplifier to a 100mV step input with a common-mode input of -200mV?
7. Determine the poles and zeros using a Spice analysis for both the open-loop and closed-loop amplifier. The feedback should provide a dc gain of +1. Plot the two dominant open-loop and closed-loop poles.